

# **ITC-x14-PH2A Dual Ethernet Intelligent Video Parking Detector Installation Manual**

**Ver1.1**

## Table of Contents

Chapter 1 Introduction.....	- 4 -
1.1 Objective .....	- 4 -
1.2 Scope of Application .....	- 4 -
1.4 Device Structure.....	- 4 -
1.4.1 Appearance .....	- 4 -
1.4.2 Structure .....	- 5 -
Chapter 2 Device Installation.....	- 10 -
2.1 Specifications.....	- 10 -
2.1.1 130/ 2.00 MP Intelligent Video Parking Detector.....	- 10 -
2.1.2 3.00 MP Parking Detector .....	- 11 -
2.1.3 Non-standard Plan .....	- 12 -
2.1.4 Inclined Parking Plan .....	- 13 -
2.2 Installation Method .....	- 13 -
2.2.1 3rd Generation Parking Installation Method.....	- 13 -
2.2.2 Dual Axis, Lens Detail .....	- 15 -
2.3 Power Supply and Networking Wiring.....	- 16 -
Chapter 3 Debug System.....	- 17 -
3.1 Camera Parameter Setting.....	- 17 -
3.2 Intelligent Traffic Property Config.....	- 18 -
3.2.1 Intelligent Analysis “Scene Config” .....	- 18 -
3.2.2 Intelligent Analysis “Recognition Config” .....	- 19 -
3.2.2 Parking Property Setting .....	- 19 -

3.2.3 Indicator Control Parameter .....	- 20 -
3.2.4 Picture OSD Overlay Setup .....	- 21 -
3.3 Parking Detector Program Upgrade.....	- 22 -
3.3.1 Quick Config Tool .....	- 22 -
3.3.2 Batch Modify .....	- 24 -
3.3.3 Upgrade Device .....	- 25 -
3.3.4 Default Config .....	- 27 -
3.3.5 Before Upgrade .....	- 28 -

## Chapter 1 Introduction

### 1.1 Objective

To instruct the engineering and technical personnel, engineering refer to standard construction, device installation to meet regulatory requirements, to ensure construction quality.

### 1.2 Scope of Application

This manual is for ITC214-PH2A, ITC314-PH2A-F3, ITC314-PH2A-TF2/3, ITC114-PH1C, ITC314-PH1C, 3<sup>rd</sup> generation 48V network power supply plan, see below.

#### Power Supply

- DH-ITC114-PH1B, DH-ITC314-PH1B, DH-ITC114-PH1C, DH-ITC314-PH1C series 2<sup>nd</sup> generation parking detector standard supports DC 12V, suitable for DC 12V – DC 24V non-standard voltage.
- DH-ITC214-PH2A, DH-ITC314-PH2A, DH-ITC314-PH2A-TF2, DH-ITC114-PH1C, DH-ITC314-PH1C series 3<sup>rd</sup> generation parking detector standard supports DC 48V, suitable for DC 12V – DC 24V non-standard voltage.

#### Cascading

- DH-ITC114-PH1B, DH-ITC314-PH1B, DH-ITC114-PH1C, DH-ITC314-PH1C series 2<sup>nd</sup> generation parking detector support network cascading, device quantity  $\leq 20$  units, cascading network total length  $< 100\text{m}$ ; network link connection, built-in network bypass function, in case of device failure or outage, link can normally communicate.
- DH-ITC114-PH1C, DH-ITC314-PH1C series 3<sup>rd</sup> generation parking detector supports network cascading power supply, device quantity  $\leq 12$  units.
- DH-ITC214-PH2A, DH-ITC314-PH2A series 3<sup>rd</sup> generation parking detector supports network cascading power supply, device quantity  $\leq 10$  units.
- DH-ITC314-PH2A-TF2 series 3<sup>rd</sup> generation parking detector device supports network cascading, device quantity  $\leq 6$  units.

### 1.4 Device Structure

#### 1.4.1 Appearance

3<sup>rd</sup> generation parking detector appearance is in 1.4-1 :



Figure 1.4-1 single eye



Figure 1.4-2 dual eyes



## 1.4.2 Structure

### 1.4.2.1 3<sup>rd</sup> Generation Camera Unit

Camera unit is in Figure 1.4-2 :

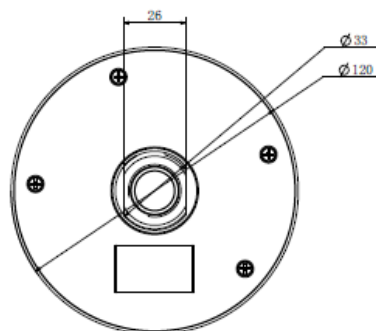
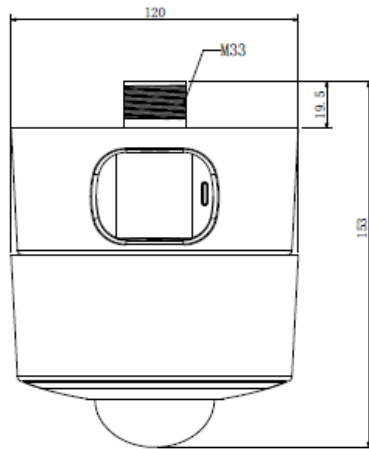
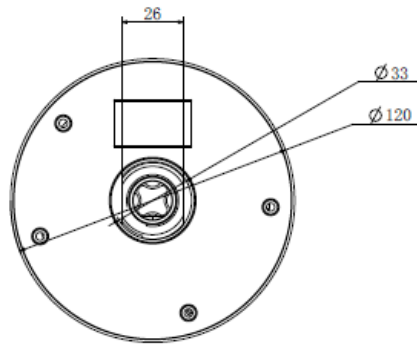
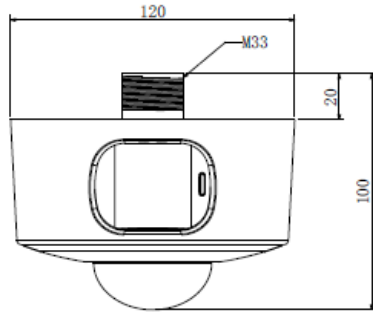

**浙江大华技术股份有限公司**  
ZHEJIANG DAHUA TECHNOLOGY CO.,LTD.

Figure 1.4-3 Dual Ethernet intelligent video parking detector unit structure

### 1.4.2.2 Install Bracket

Install bracket as in Figure 1.4-3 :

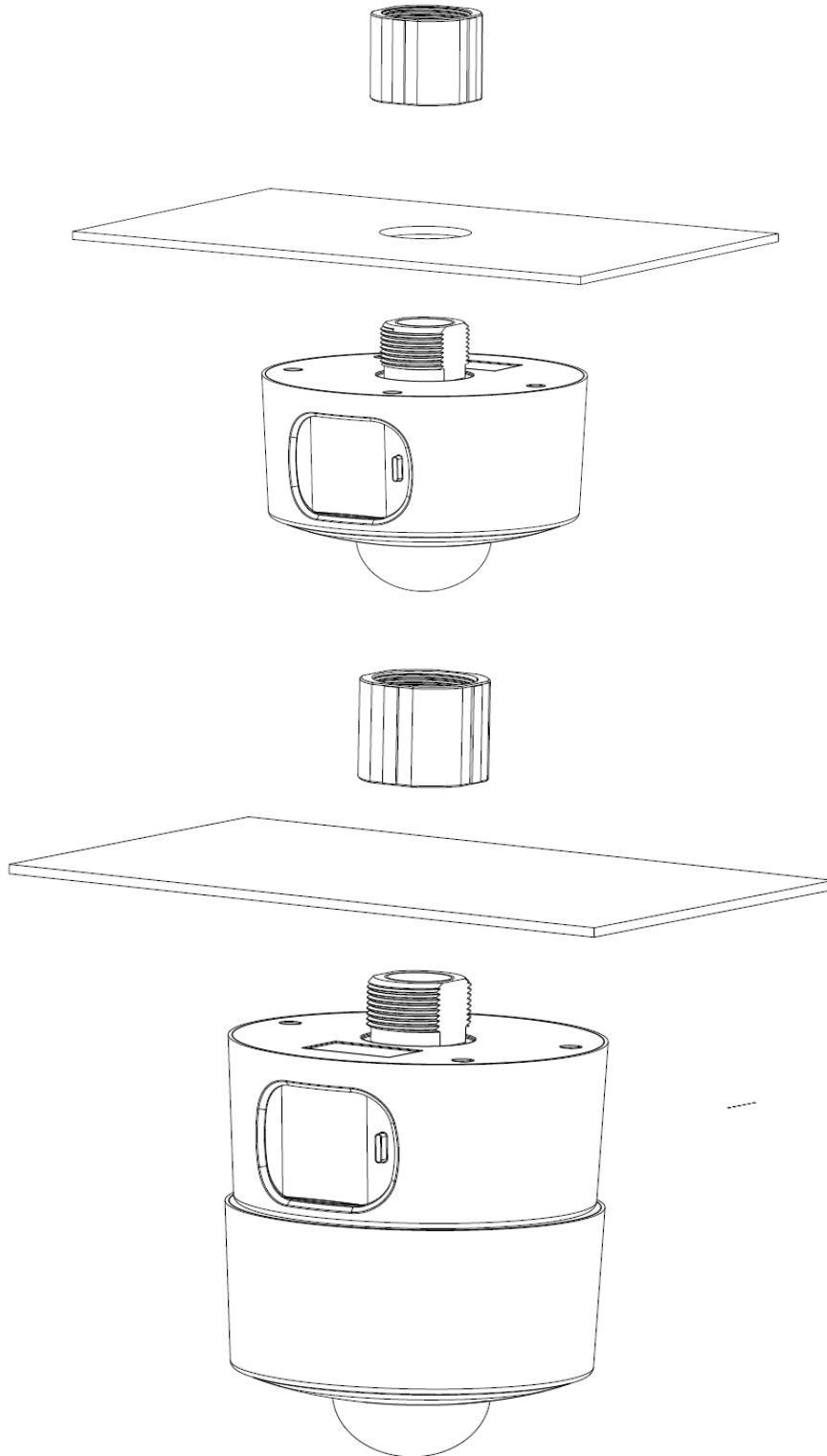
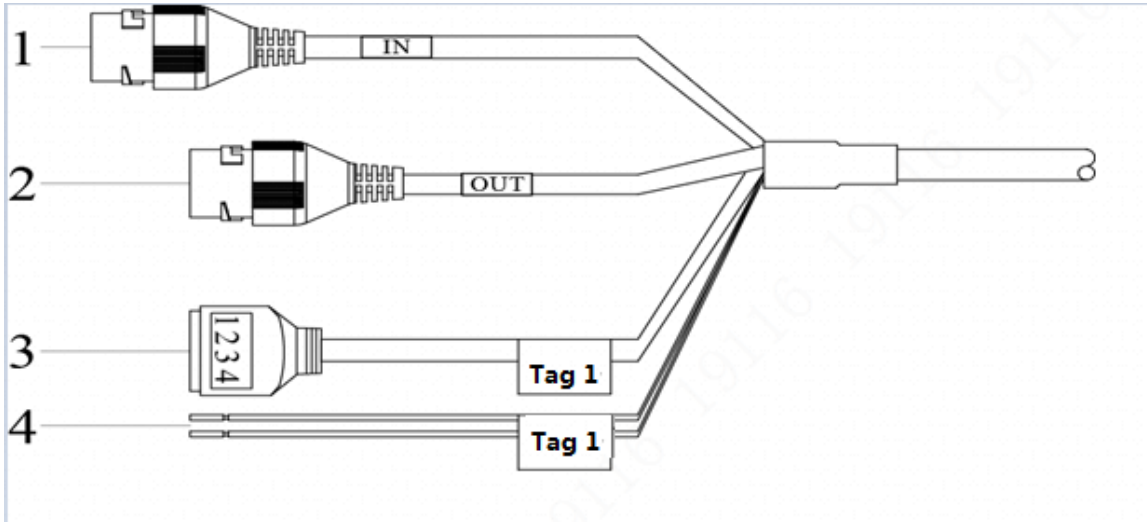

Figure 1.4-4 Install brocket structure

### 1.4.2.3 Power Ethernet Cable Port



No.	N	Name	Cable Note
1		Ethernet Port (IN)	Network power supply input
2		Ethernet Port (OUT)	Network power supply output
3		Power Port	1 : 48V_IN. 2 : GND_IN. 3 : 48V_OUT. 4 : GND_OUT.
4		RS485 Port	<ul style="list-style-type: none"> <li>● Yellow : RS485_A.</li> <li>● Orange : RS485_B.</li> </ul>



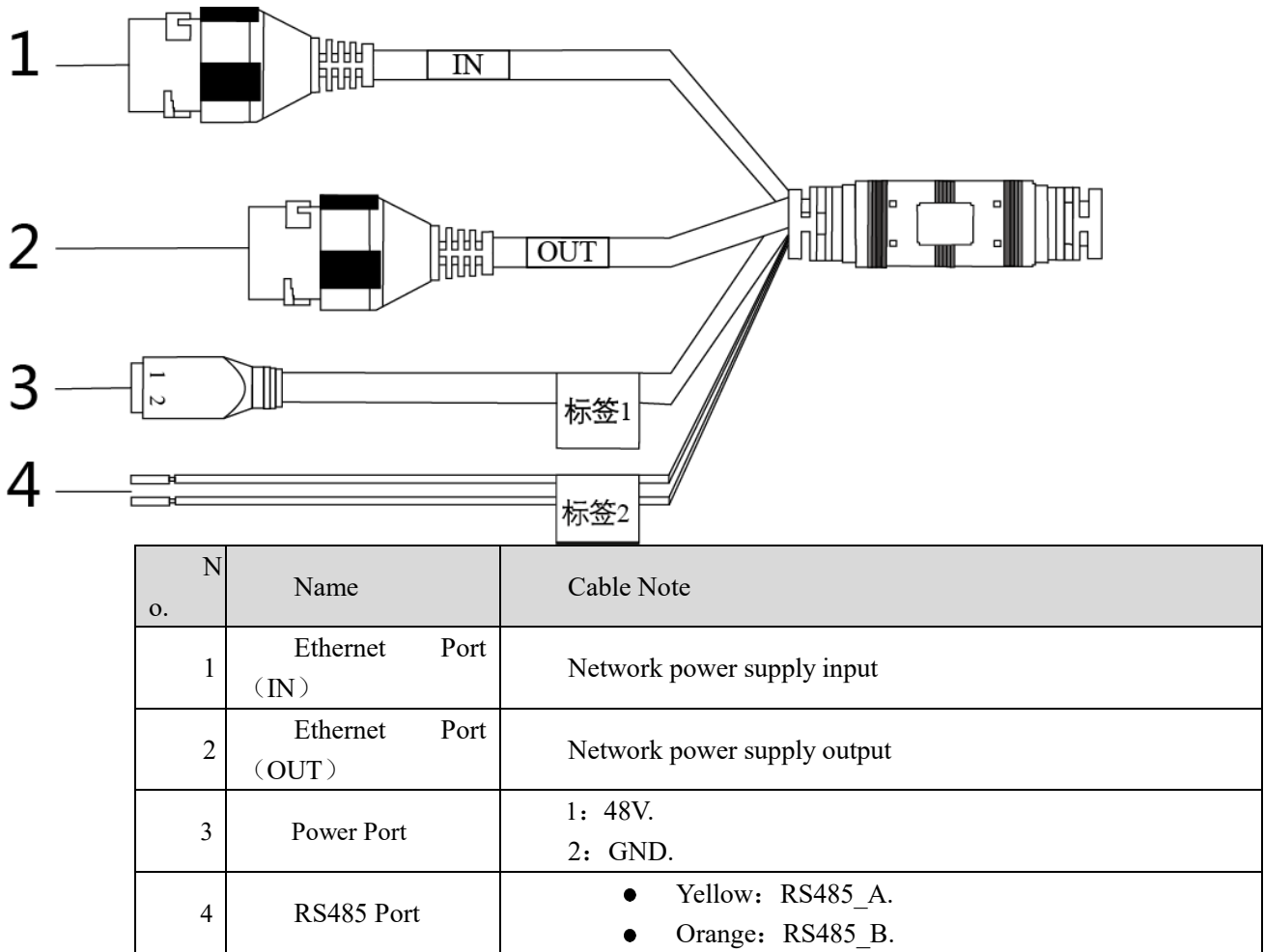

Figure 1.4-5 Power Ethernet port

## Chapter 2 Device Installation

### 2.1 Specifications

**Note :** Installation must match the following requirements

- 1 . Within monitoring range, horizontal distance shall be higher than vertical distance.**
- 2 . Plate pixel matches 130-170 ( NK algorithm )**

#### 2.1.1.130/ 2.00 MP Intelligent Video Parking Detector

114/214 series intelligent video parking detector is recommended to have 2 lanes, and device being monitored is in the center of lane at a certain distance to the parking. Perpendicular to parking at 2.3~2.6 meters height of bridge or wall top, see Figure 2.1-1 :

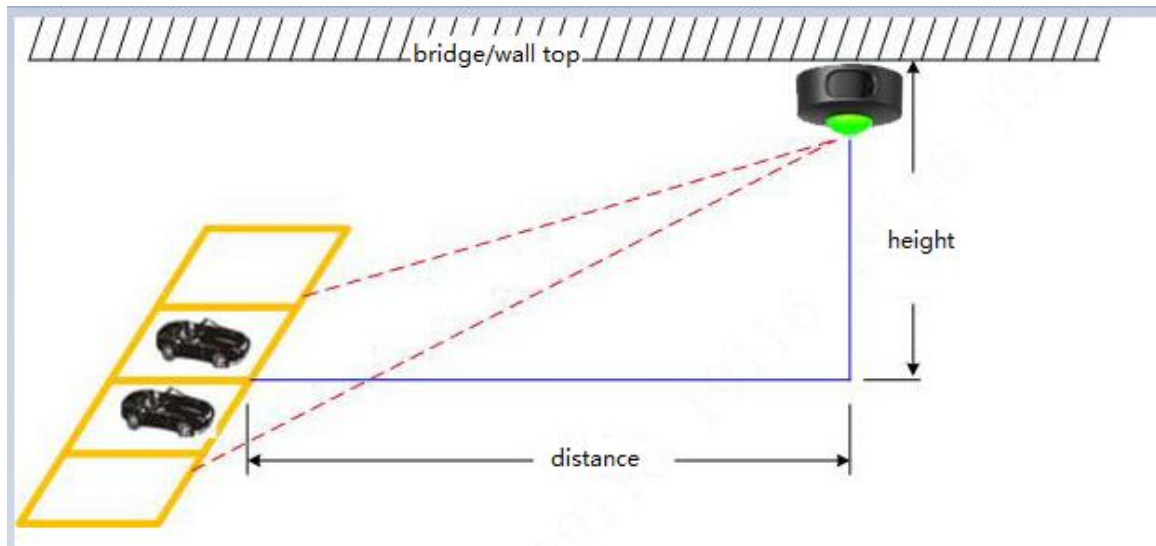

Figure 2.1-1 Installation specifications

To meet needs of different scenes, the device is equipped to 2 types of lens, as 3.6mm and 6mm. In addition to model, it has 3.6mm fixed-focus lens, and model name ended in F3 has 6mm fixed-focus lens. For example a model name ended in F6 as ITC214-PH2A-F3 device has 3.6mm lens. .

Since the difference between lens focal length and resolution, the devices vary in installation, please be careful to their installations. Installations are as follows :

Model	Resolutio n	Focal Length	Installation Method			Not e
			Horizontal	Vertical	Monitoring Width	
Example	n	Length				e

			Distance	Height		
Two Parking	1920×1080	6mm	4.8~6.5 meters	2.3~2.6 meters	Cover two parking 5m	
		4 (3.6) mm	3.0~4.7 meters	2.3~2.6 meters	Cover two parking 5m	
	1280×960	6mm	4.5~5 meters	2.3~2.6 meters	Cover two parking 5m	
		4 (3.6) mm	3~3.8 meters	2.3~2.6 meters	Cover two parking 5m	

Chart 4 1. 30 and 2.00 MP parking detector installation plans

### 2.1.2 3.00 MP Parking Detector

314 series intelligent video parking detector can monitor 3 parking while device must be in the center of parking, at a certain distance to the parking. Install at bridge or wall top of vertical height of 2.5~2.6 meters over parking, see Figure 2.1-2 :

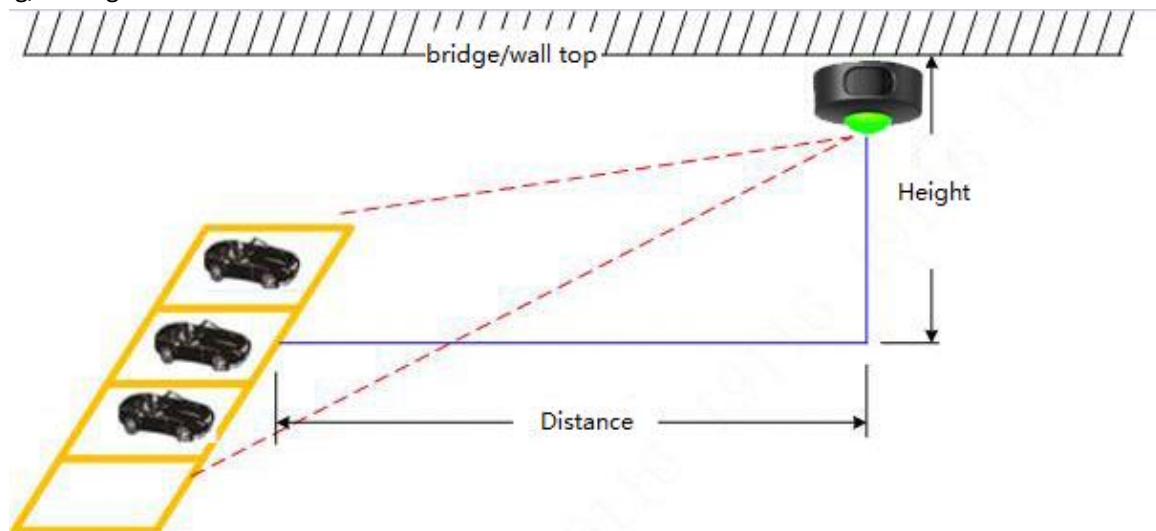

Figure 2.1-2 Installation specifications

Besides installation distance, there are two factors will influence 3.00 MP intelligent video parking detector monitoring scenes, see below :

- 1 ) Lens focal length, suitable for different monitoring scenes , 3.00 MP intelligent video parking detector has 2.8mm, 3.6mm two types of lens ;
- 2 ) 3.00 MP parking detector has different lens, and user requires different resolutions and installation plans are shown in :

Model Example	Resolution	Focal Length	Installation Plan			Note
			Horizontal Distance	Vertical Height	Monitoring Width	
Three Parking	2048×1536	4 (3.6) mm	3.5~5.2 meters	2.5~2.6 meters	Cover three parking 7.5m	
		2.8mm	2.5~3.5 meters	2.5~2.6 meters	Cover three parking 7.5m	

Chart 5 3.00 MP intelligent video parking detector installation plans

Default camera resolution is 2048×1536 and we recommend 2048×1536 in actual application !

### 2.1.3 Non-standard Plan

No.	Camera Model	Focal Length	Plate Pixel Corresponding			Note
			Horizontal Distance			
			130pxi	150pxi	170pxi	
1	3 parking	2.8mm	3.5 meters	2.4 meters	3.4 meters	At place of 6mm lens 5m, plate pixel is 200pxi, recommended to install at horizontal distance over 6.5m.
		4mm	4.5 meters	3.85 meters		
2	2 parking	2.8mm	3 meters	2.5 meters	2 meters	
		4mm	4.5 meters	3.85 meters	3.4 meters	
		6mm				

### 2.1.4 Inclined Parking Plan

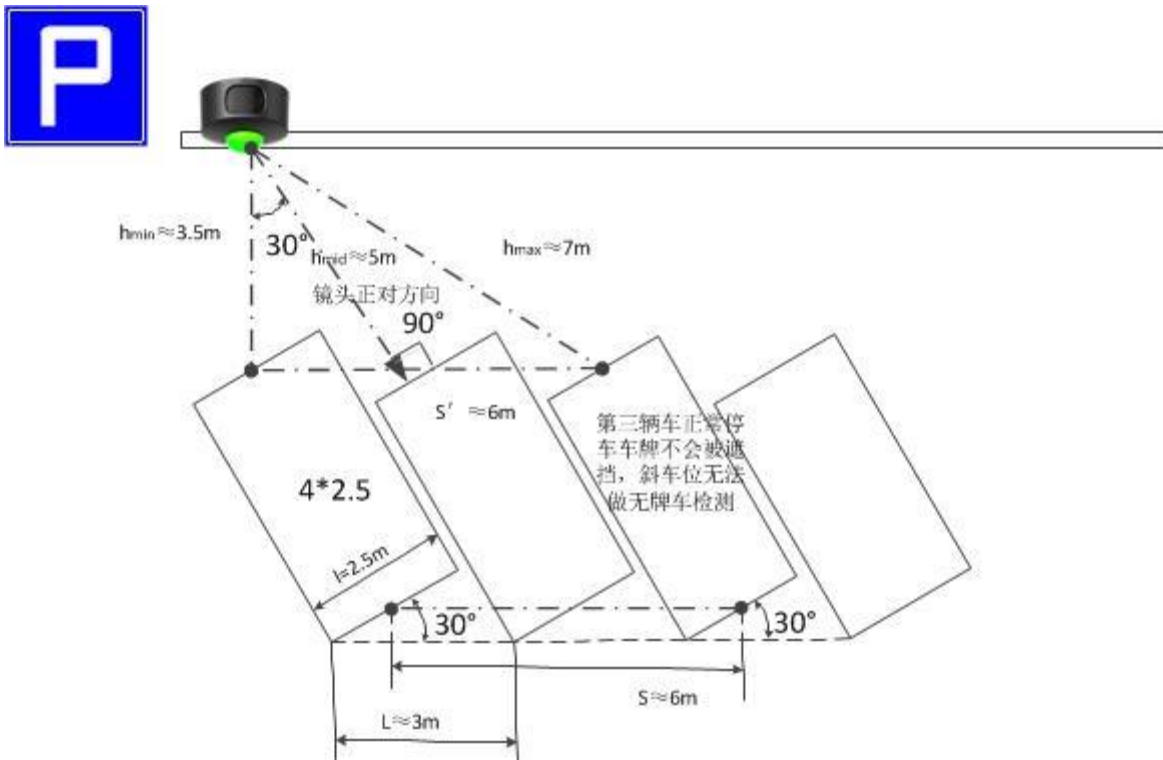

Warning : Inclined parking three parking plan actually measures ( plate width is 52cm ) and the farthest plate pixel is about 95pxi , and the closest plate pixel is about 135pxi. Although it can normally identify plate pixel during test, it does not match best identification pixel range ( 130-170pxi ) of algorithm , so we strongly recommend that only detect two angled spaces.

## 2.2 Installation Method

### 2.2.13rd Generation Parking Installation Method

Warning

Parking detector is installed on bridge, and the surface of installation must be able to bear 3X weight of the device..

At device installation position, use a drill to open a hole with diameter of 35mm on bridge.

Note

Screw hole diameter is 33mm.

Drill hole

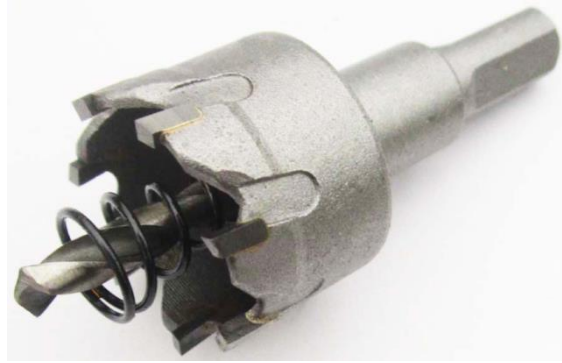

Pull cable of parking detector through the hole on bridge..

#### Installation 1

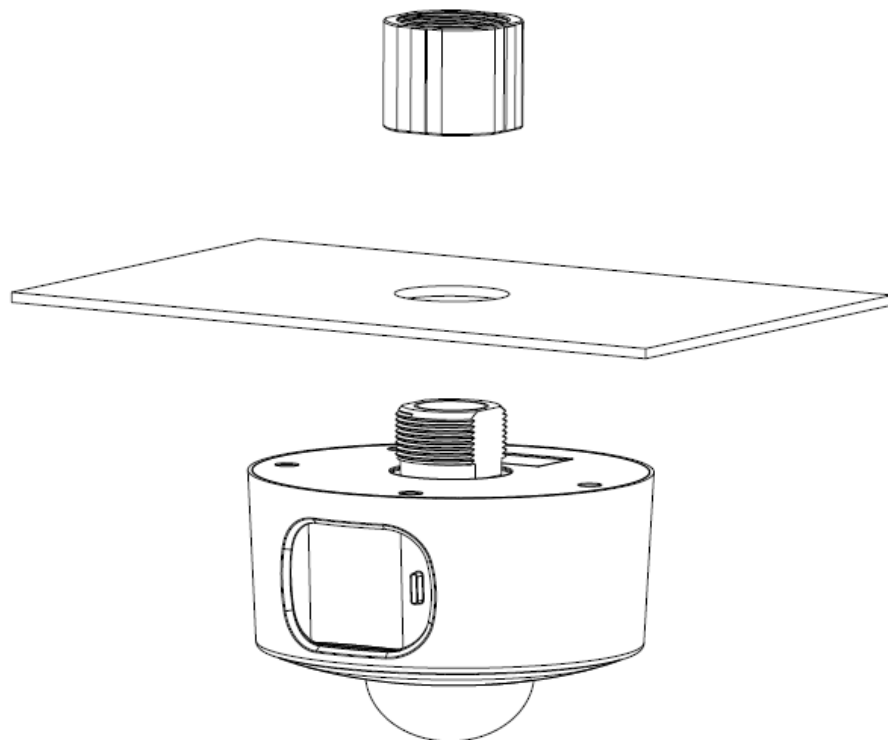

Take out screw, pull cable through the hole and fix on bridge.

#### Installation 2

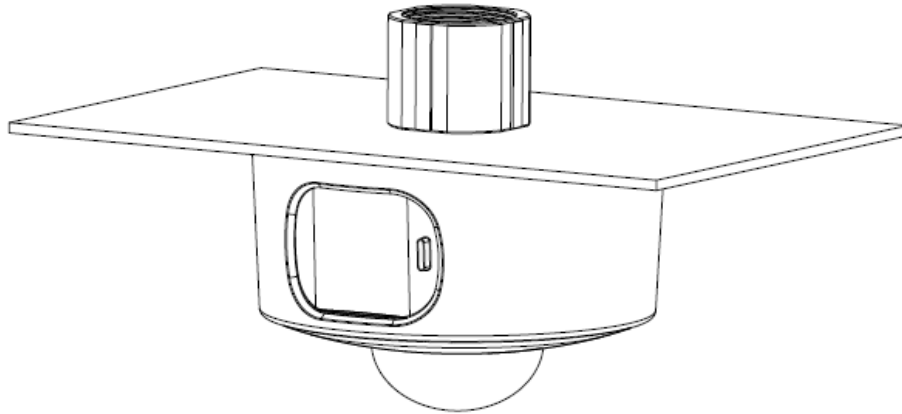

Refer to Ch 错误!未找到引用源。 for cable connection.

Open dome cover, according to parking detector position, you can adjust monitoring viewing angle.

Put back cover. .

### 2.2.2 Dual Axis, Lens Detail



## 2.3 Power Supply and Networking Wiring



Cascading method

Note :

- 1、 DH-ITC114-PH1C, DH-ITC314-PH1C series 3<sup>rd</sup> generation parking detector only needs one device for power supply (DC48V power), network supports cascading power supply, device quantity  $\leq 12$  units.
- 2、 DH-ITC214-PH2A, DH-ITC314-PH2A series 3<sup>rd</sup> generation parking detector only needs one device for power supply (DC48V power), network supports cascading power supply, device quantity  $\leq 10$  units.
- 3、 DH-ITC314-PH2A-TF2 series 3<sup>rd</sup> generation parking detector only needs one device for power supply (DC48V power), network supports cascading power supply, device quantity  $\leq 6$  units.
- 4、 Dahua standard 48V power adaptor includes material no. : 1.2.19.07.10050
- 5、 Manufacturer self-equipped 48V 2A.



## Chapter 3 Debug System

### 3.1 Camera Parameter Setting

When intelligent video parking detector is well installed, you need to check if the device connects to network normally, and the default IP address is "192.168.1.108". IP setting page is in Figure 3.1-1.

Parameter	Note
Host Name	Set host device name, max 15 characters.
Ethernet Card	Select Ethernet card, default is wired.
Mode	<p>Network mode, include static and DHCP.</p> <ul style="list-style-type: none"> <li>• Static mode: manually set IP address, subnet mask, gateway, click "OK", WEB page will auto go to new IP address login interface.</li> <li>• DHCP mode: auto get IP address. When you enable DHCP "IP address", "subnet mask" and "default gateway" cannot be set. No matter DHCP is valid or not, you always can view current IP address.</li> </ul>
MAC Address	Show host MAC address, cannot be changed.
IP Version	IP version, include IPv4 and IPv6, two versions of IP can be accessed.
IP Address	Enter device IP address.
Subnet Mask	<p>According to actual condition setting, prefix of subnet is number, enter 1~127, prefix of subnet represents a specific network link, generally includes one-layer structure.</p> <p>Note:                      Device will check validity of all IPv6 address, and IP address and default gateway must be in the same segment, as their some digits of prefix of subnet must be same.</p>

Parameter	Note	
Default Gateway	Set device IP address corresponding default gateway	Note IPv6 version has no default gateway, preferred DNS, alternate DNS enter 128 digits, cannot be null.
Preferred DNS Server	DNS server IP address.	
Alternate DNS Server	DNS server alternate IP address.	

Figure 3.1-1

## 3.2 Intelligent Traffic Property Config

### 3.2.1 Intelligent Analysis "Scene Config"

When a parking detector is detecting, through drawn virtual area line, it detects parking and vehicle status, and via "config recognition", set no-plate vehicle snapshot and recognition of place of plate vehicle.

Parking detector intelligent analysis scene config path : WEB→ITC→Intelligent→Intelligent Analysis→Scene , See Figure 3.2-1 :

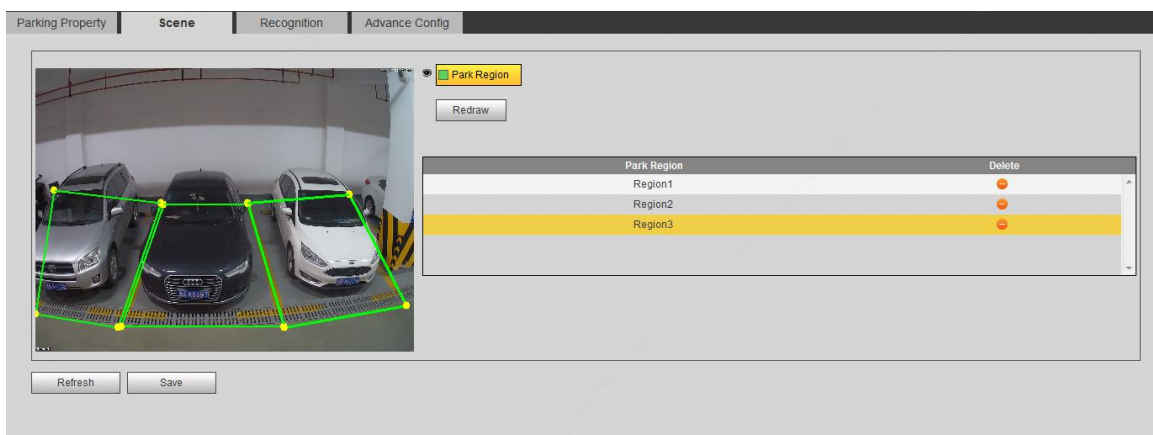

Figure 3.2-1 scene config

Set intelligent rule :

- ✧ Step 1 Click "Intelligent Analysis" button to go to "Scene" interface ;
- ✧ Step 2 Click "Redraw" button, delete original default virtual parking ;
- ✧ Step 3 On actual parking, draw virtual parking , method : place mouse on one side boundary of virtual parking, long press left key and drag mouse to the end of the boundary, release mouse. Now you complete one virtual line drawing and draw the other 3 boundary accordingly. Click left key on mouse to close the rectangle. △Note : You can only draw quadrangle parking.
- ✧ Step 4 click "OK" to save config.

- ✧ Step 5 for For letter and number on ground, please draw shield area to avoid miss report of parking (max of 6 shield area in a parking space). Shield area only blocks letter, number, flood drain and water, not block plate.

### 3.2.2 Intelligent Analysis“Recognition Config”

See Figure 3.2-2 :

Figure 3.2-2 Recognition

General parameter note :

Parameter	Note
No-plate Vehicle Snapshot	Check to enable no-plate vehicle snapshot. “NO-plate vehicle detection sensitivity” is AUX of “no-plate vehicle snapshot”, provides “high, mid, low” levels of sensitivity. Camera has default level of “low” , and user can set level. Be aware that high sensitivity leads to miss alarm problems.

Chart 7 Recognition config general parameter note

### 3.2.2 Parking Property Setting

During actual usage, for better positioning, you shall edit parking no. of camera monitoring parking and edit area of each parking location. You also need to respond user application , modify camera snapshot event. And in parking detector’s “parking property” page, it provides customization of above parameter.

“Parking Property” parameter path : WEB→setup→ITC→Parking , page see Figure 3.2-3 :

Figure 3.2-3 Set parking property

Event config has "occupied parking" or "free parking" event "advanced config" page :

图 3.2-4 高级配置

Parameter note see Chart 8 :

Parameter	Note
No-plate Vehicle Detection Sensitivity	Check no-plate vehicle sensitivity. The higher the value, the slower the detection speed will be, but stability will be higher.
Plate Detection Sensitivity	Detect vehicle sensitivity. The higher the value, the slower the detection speed will be, but stability will be higher.
No Vehicle Detection Sensitivity	Detect no vehicle sensitivity. The higher the value, the slower the detection speed will be, but stability will be higher.

Chart 8 Advanced parameter note

### 3.2.3 Indicator Control Parameter

System config plan has external indicator, and accustomed parking indicator color of user which will switch color when the parking is free or occupied. These parameters are linked to parking detector indicator parameters.

Change of parking detector indicator is in light control interface, see path: WEB→Setting→ITC→Light Control , see Figure 3.2-5 :

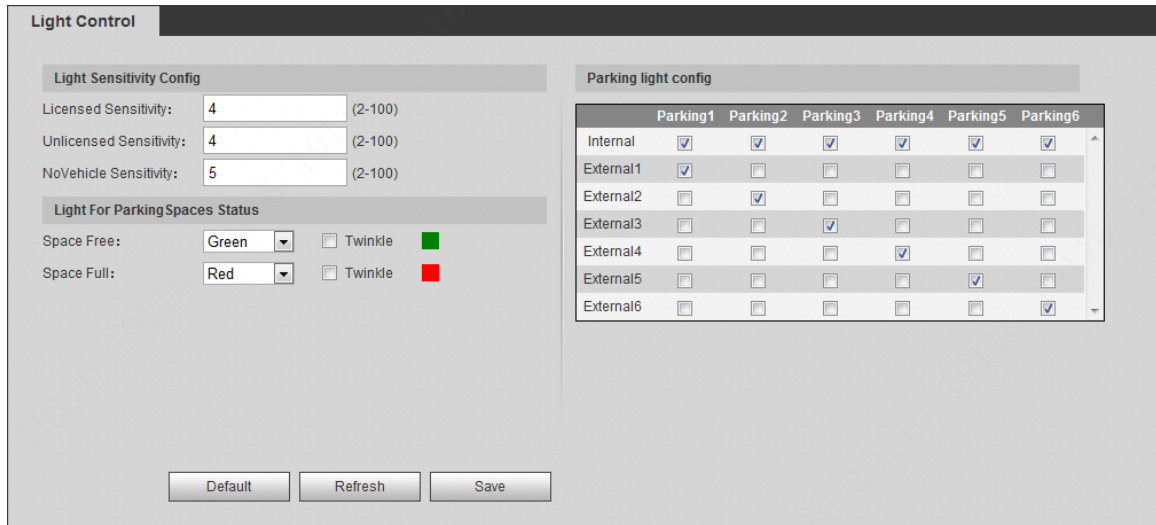

Figure 3.2-5 Indicator control

Chart 9 :

Parameter	Note
Free parking, Occupied parking	Set two parking indicator status
Indicator Color	Indicator color includes red, yellow, blue, green, cyan, white, pink and off.
Flash	<ul style="list-style-type: none"> <li>● Select “Flash” , indicator starts to flash.</li> <li>● Select “off” , indicator normally on.</li> </ul>

Chart 9 Indicator control parameter status

### 3.2.4 Picture OSD Overlay Setup

Parking detector has picture info overlay function, so a user may set OSD info according to his need. Picture info is set in “OSD” interface, path: WEB→Setting→ITC→OSD Parameter , see Figure 3.2-6 :

OSD Select

OSD Select

General Info

Time       Parking No.       Parking Zone

Address

Extend Info

Plate       Vehicle Color       Vehicle Size

Vehicle Sign       Parking Status       Country

Font

32

Refresh      Save

Figure 3.2-6 Snapshot setup

## 3.3 Parking Detector Program Upgrade

### 3.3.1 Quick Config Tool

- Step 1. Click .
- System shows “Modify IP Address” interface.
- Step 2. Click “Setting” .
- System shows Setting box, see Figure 0.

Figure0 Setting

The 'Setting' dialog box contains the following fields and options:

- Two checked checkboxes:  Current Segment Search and  Other Segment Search.
- Start IP: 192 . 168 . 4 . 1
- End IP: 192 . 168 . 4 . 100
- Username: admin
- Password: [masked with 6 dots]
- An 'OK' button at the bottom right.

Step 3. Set device segment, login username and password, click “OK” .  
After search is complete, system shows searched device.

Note

- Default username and password are admin and admin.
- For device requires initialization, please initialize it first.

Step 4. Click  of IP to be modified.

See Figure0.

Figure0

The 'Modify IP Address' dialog box contains the following fields and options:

- Mode:  Static and  DHCP.
- Target IP: [empty field]
- Subnet Mask: [empty field]
- Gateway: [empty field]
- A status bar at the bottom shows 'Selected number of devices: 1'.
- An 'OK' button at the bottom right.

According to actual condition, select IP address mode.

- DHCP (Dynamic Host Configuration Protocol) mode: current network has

DHCP server, set “mode” to “DHCP”, then device gets IP address automatically from DHCP server.

- Manual mode: set “mode” to “static”, and fill in device “target IP”, “subnet mask” and “gateway”, then device IP address is changed to the set IP.

Step 5. Click “OK” to complete.

### 3.3.2 Batch Modify

Step 1. Click .

See “Modify IP Address” interface.

Click “Search Setting” .

See Figure 0.

Figure0 Setting

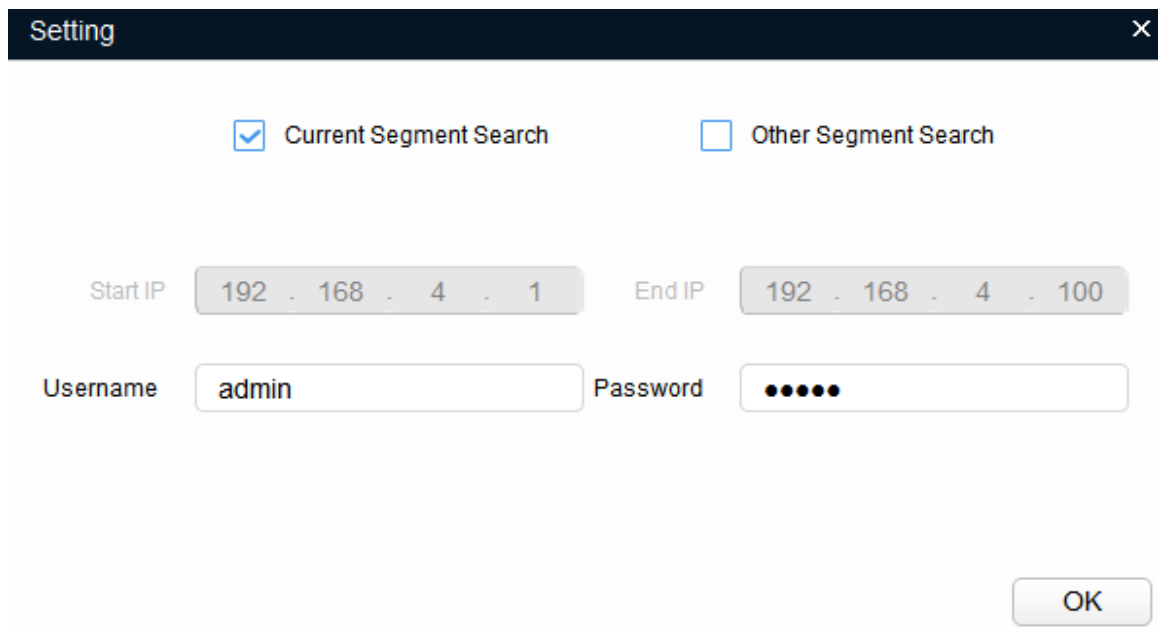

The screenshot shows a 'Setting' dialog box with the following elements:

- Header: Setting (with a close button 'x')
- Options:
  - Current Segment Search
  - Other Segment Search
- IP Range:
  - Start IP: 192 . 168 . 4 . 1
  - End IP: 192 . 168 . 4 . 100
- Authentication:
  - Username: admin
  - Password: [masked]
- Buttons: OK

Set device segment, login username and password, click “OK” .

After search is complete, system shows searched device.

Note

- Default username and password are admin and admin.
- For device requires initialization, please initialize it first.

Select device to be modify, click Batch Modify IP.

See Figure 0.



Figure 3.3-5 Modify IP

According to actual condition, select IP address mode.

- DHCP (Dynamic Host Configuration Protocol) mode: current network has DHCP server, set “mode” to “DHCP”, then device gets IP address automatically from DHCP server.
- Manual mode: set “mode” to “static”, and fill in device “start IP”, “subnet mask” and “gateway”, then device IPs starting from the start IP addresses are changed ascendingly .

Note:

Select “same IP”, and set selected device(s) to the same IP.

Click “OK” to complete.

### 3.3.3 Upgrade Device

You can upgrade one by one or as a batch.

- Step 1. Click , system shows upgrade interface, see Figure0.

Figure 3.3-6 Upgrade



Select device to be upgraded.

- Single upgrade: click Open of device you want to upgrade.
- Batch upgrade: select device you want to upgrade, and click “batch upgrade”.

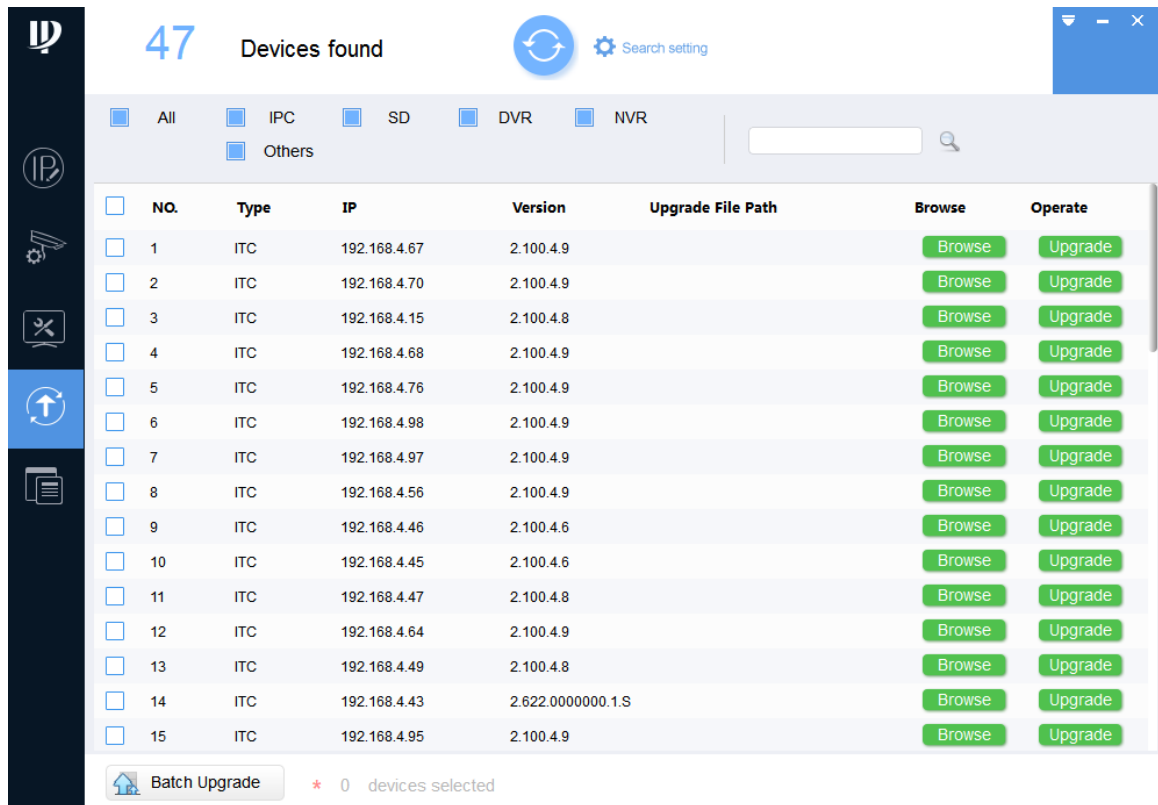
Select upgrade file, see Figure 0.

Figure 0 Select upgrade file

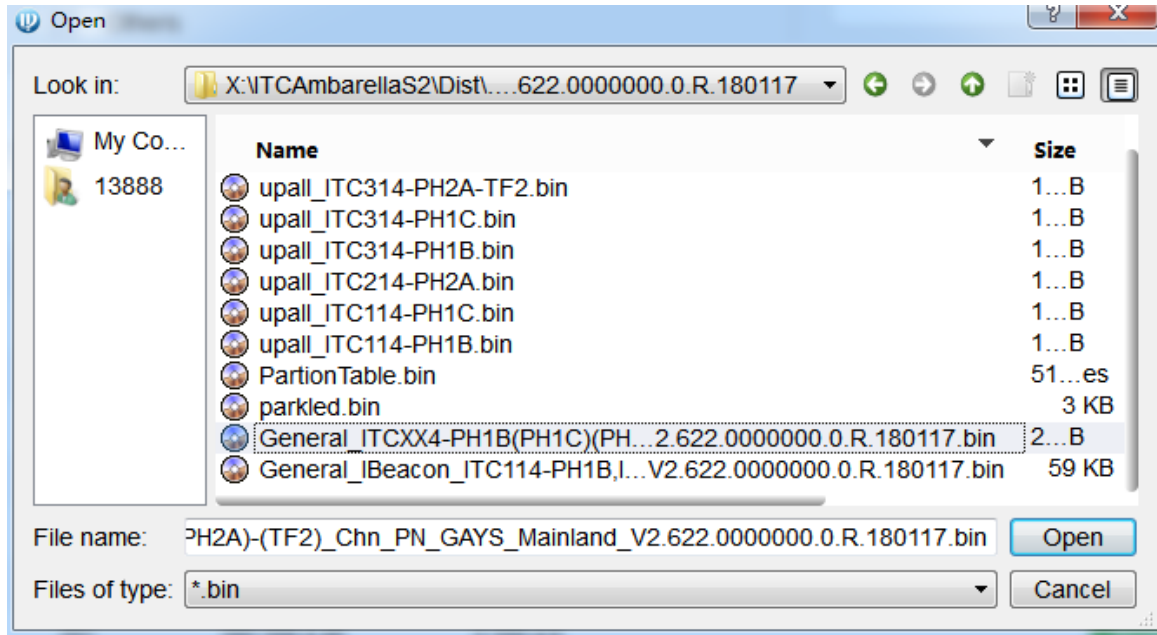

Upgrade device.

- Single upgrade: click “Upgrade”, system starts to upgrade and show progress.
- Batch upgrade: click “OK”, system starts to upgrade.

Note:

During upgrade process, if the device disconnects, and as long as ConfigTool stays in this interface, when the device connects again, the process will continue.

### 3.3.4 Default Config

After device upgrade is complete, you shall restore default setting and reboot the device. You can restore default via the following methods :

#### Software Reset

After upgrade is complete , log in the device on WEB.

Click “System Manager”, select “Default” tab, click Default button. See Figure 3.3-8 :

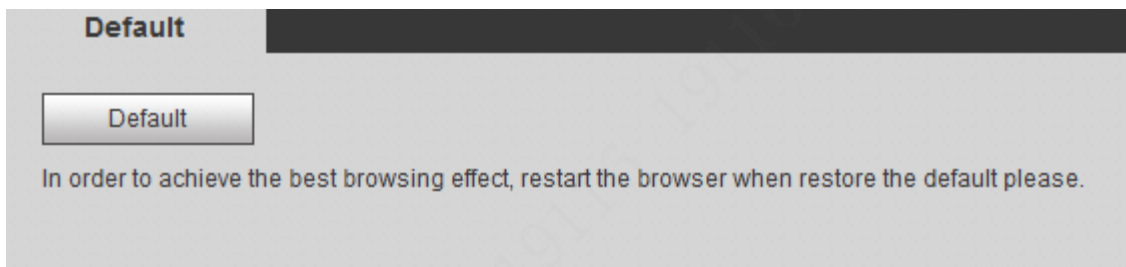

Figure 3.3-8 Software reset

### 3.3.5 Before Upgrade

1. If device system upgrading fails, please check for causes. If upgrade file is wrong, please switch to correct version of upgrade file, and upgrade device again. If device operates as normal, and there is still other cause of failure of upgrade, please reboot Quick Config Tool to log and upgrade the device.
2. After system upgrade is complete, you shall restore default settings of device.  
The above two methods are both available for your selection.